

# Sonya



# Sonya



## Comfort

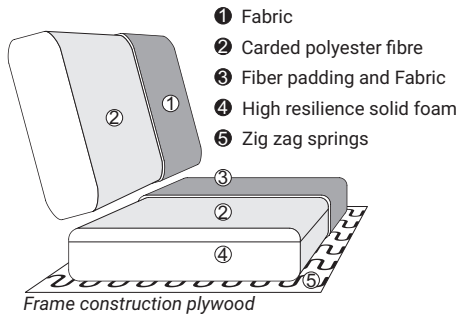

Frame construction plywood

French seam (1,5 cm) on armrest, back cushions and seats

Specific comfort construction of the superior layer of the seat cushion might get loose fabric effect in a short time, which is a natural effect and considered as esthetic standard.

## Extra dimensions

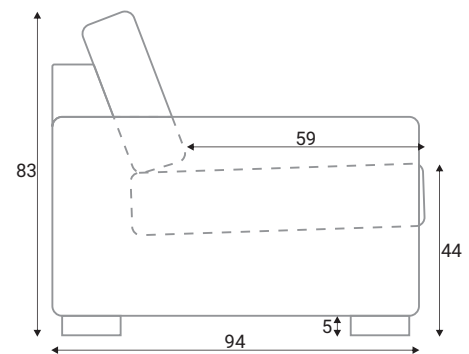

## Legs



**WM02**  
Plywood,  
chrome finishing

## Accessories

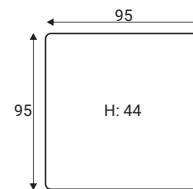

**Footstool F33**

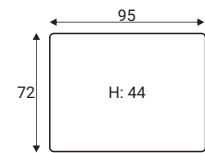

**Footstool F32**

## Modules

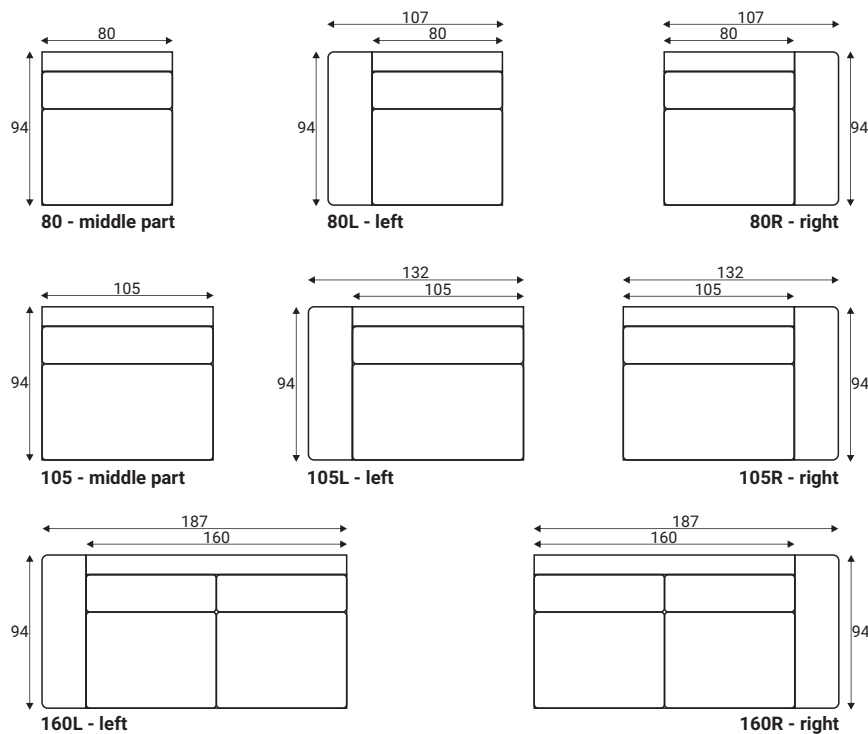

reserves the right to change construction of products and components used due to improving durability of product and customer satisfaction without any further notice. Upholstered furniture is handmade using soft materials there fore measurements may vary up to +/- 3cm. Slight colour variations may occur between production batches. For technological reasons variations in color shades are acceptable.



# Sonya

## Modules

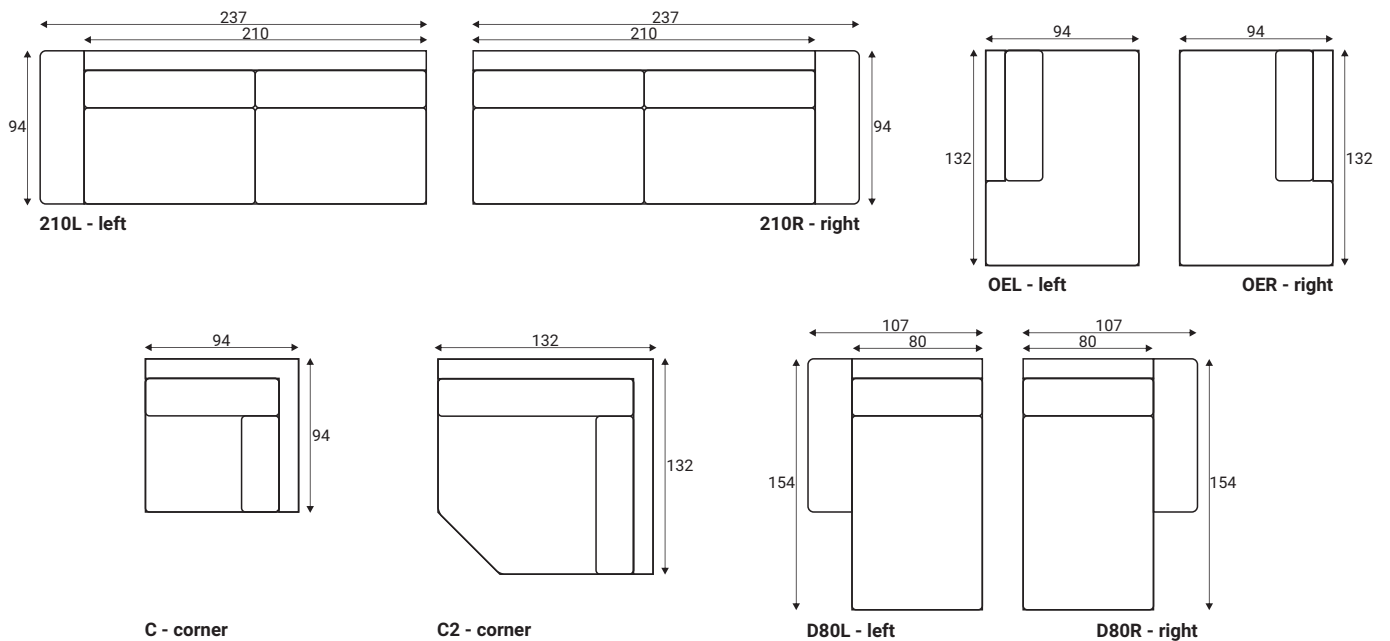

## Standard sets

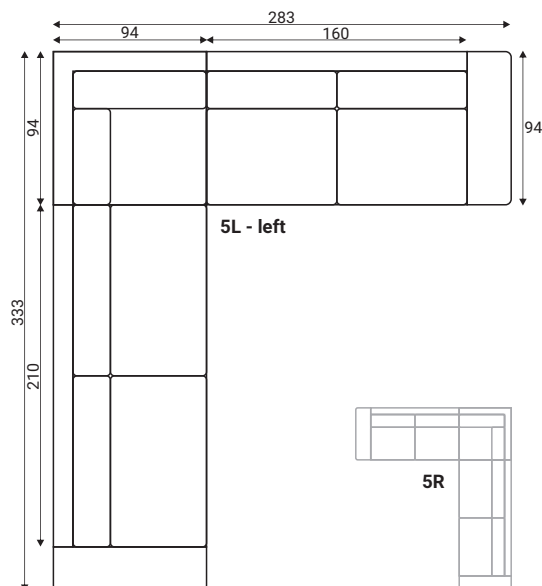

## Furniture features in symbols



- Seat and back cushions are loose from the frame.



- Removable cover for loose cushions.  
(For maintenance please check fabric information.)



- Fabric



- Modular system

reserves the right to change construction of products and components used due to improving durability of product and customer satisfaction without any further notice. Upholstered furniture is handmade using soft materials there fore measurements may vary up to +/- 3cm. Slight colour variations may occur between production batches. For technological reasons variations in color shades are acceptable.